

### Features

- Washout urinal
- 3/4" (19 mm) rear spud
- 1 pint or 0.125 gpf (0.47 lpf)
- Includes inlet and outlet spuds and hangers
- Includes anti-backsplash walls
- 14-3/4" (375 mm) extended lip

### Material

- Vitreous china

### Recommended Products/Accessories

- K-23726 Drain treatment
- K-23725 Cast iron cleaner



### Codes/Standards



ASME A112.19.2/CSA B45.1  
DOE - Energy Policy Act 1992  
EPA WaterSense®  
California Energy Commission (CEC)  
ADA  
ICC/ANSI A117.1

### KOHLER® One-Year Limited Warranty

See website for detailed warranty information.

### Available Colors/Finishes

*Color tiles intended for reference only.*

Color	Code	Description
	0	White
	96	Biscuit
	7	Black Black™

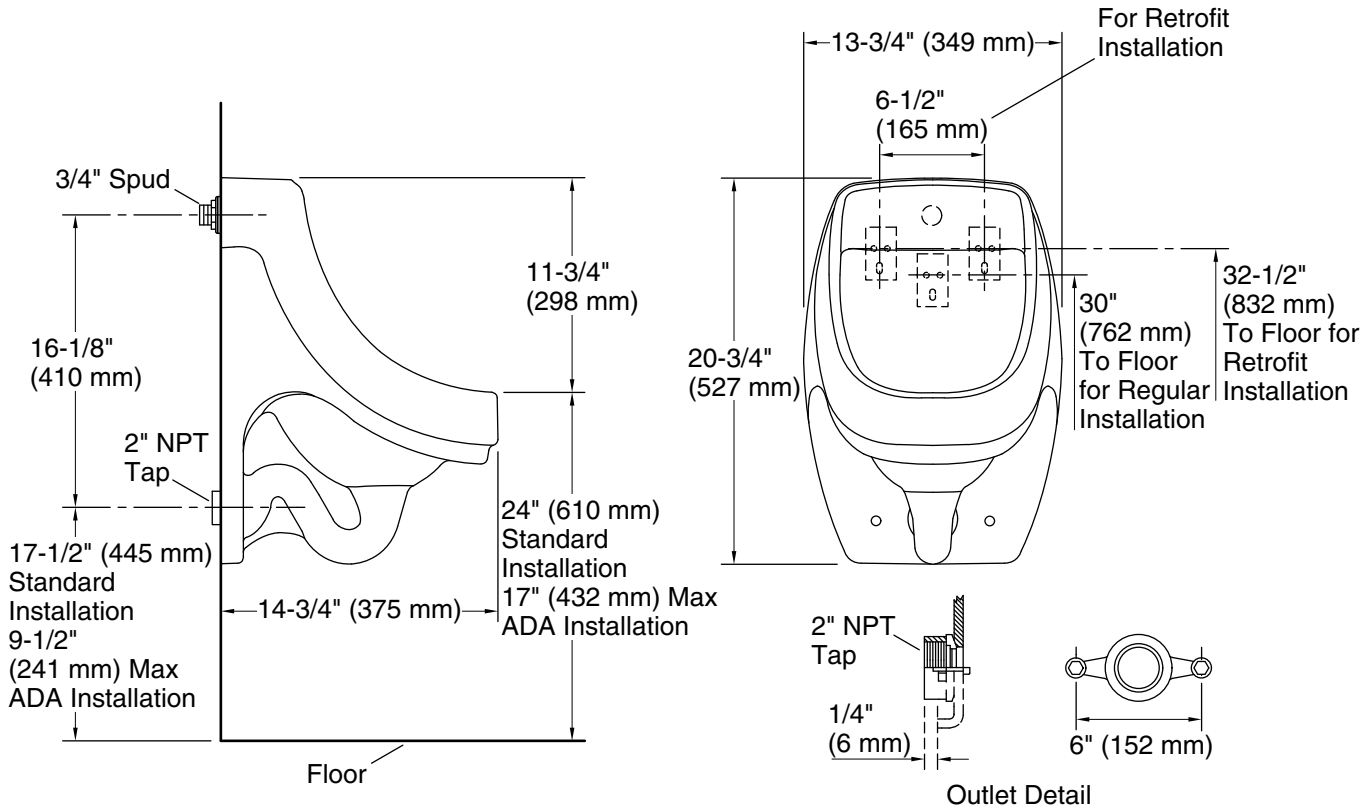

## Technical Information

All product dimensions are nominal.

Spud size:	3/4", Inlet, Rear
Min. Water per Flush:	0.125 gpf (0.5 lpf)
Max. Water per Flush:	0.125 gpf (0.5 lpf)

Designed for the above water use when installed with a water-saving flushometer.

## Pressure and Supply Requirements

Fixture pressure min (static):	25 psi (172.4 kPa)
Fixture pressure max (static):	80 psi (551.6 kPa)

## Notes

Install this product according to the installation guide.

Product dimensions are nominal and may vary per ASME A112.19.2 tolerances.

This product should be used with a WaterSense labeled counterpart with the same rated flush volume to ensure the complete system meets the requirements of this specification for water efficiency and performance.

ADA compliant when installed to the specific requirements of these regulations.