

ZURICH AND BELGRADE BATHTUB INSTALLATION GUIDE ROUGE

INSTALLATION • MAINTENANCE
REPAIR • SYSTEM



Produits Neptune
Rouge



CERTIFICATION ECORESPONSABLE

Our products have been certified ecoresponsible, recognizing Produits Neptune's initiatives towards limiting its environmental footprint.



CONSUMER CHOICE

Produits Neptune is the proud recipient of the consumer choice award.

REV: 08-20

Save these instructions for further use.



Table of Content

INTRODUCTION

Important safety information.....	2
Summary of precautions.....	2
Important information to be conserved.....	2

INSTALLATION

Tools and Materials.....	2
Preparation.....	3
Installation.....	3

MAINTENANCE

Regular cleaning.....	4
-----------------------	---

REPAIR

Stains.....	4
Small scratches.....	4
Major damage repair.....	4

TROUBLESHOOTING

Problems and solutions.....	4
-----------------------------	---

SYSTEMS

Installation.....	6
Operation.....	7
Troubleshooting.....	7

WARRANTY.....	8
---------------	---

Thank you for choosing a quality Produits Neptune Rouge product. Your confidence in us is of paramount importance to the success of our company.

You are now the proud owner of a Produits Neptune Rouge bathtub, a premiere product that will provide you with years of pleasure and relaxation if installed and maintained correctly.

Please read the safety, installation and maintenance instructions found in this guide. We highly recommend installing this product with the assistance of a specialist, in accordance to local codes, guidelines and government regulations.

To download the online version of the user guide, visit www.produitsneptune.com/rouge

The documentation is available by selecting your specific product.

IMPORTANT SAFETY INFORMATION

 **CAUTION: Always be prudent when using your bathtub and electrical appliances.**

 **CAUTION: Risk of injury or material damage.**
Please read all instructions before beginning installation, including the requirements stated below. Follow all recommendations and plumbing codes.

 **DANGER: Risk of drowning for children.** To reduce the risk of accidental drowning, do not let children use the bathtub unattended.

SUMMARY OF PRECAUTIONS

It is strongly recommended that you follow these guidelines:

- Do not operate electrical appliances (telephone, television, radio, hairdryer, etc..) within 1.5 meters (5 ft) of the bathtub.
- Never leave children unattended in the bathtub.
- To avoid damaging the finish of the bathtub, do not use abrasive cleaners.
- The water temperature must not exceed 40° C (104° F). Bathtub water in excess of these temperatures may be hazardous to one's health.
- It is important to mix the essential oils before introducing them into the bathtub. Mix the essential oils with emulsifiers (milk powder, shampoo, honey or liquid soap). DO NOT mix essential oils with milk, Epsom salts, Aloe gel or baking soda, as these products do not mix with oil. Improper use could result in skin irritation and damage to the bathtub. Please read the instructions carefully before use. Rinse the bath very well after each use. Essential oil is very abrasive and their utilisation is at risk of the user.

IMPORTANT INFORMATION

Note: Always keep your original receipt.

Date of purchase: _____ Name of the retailer: _____

Description of the bathtub: _____

Serial number and model name on the Produits Neptune Rouge logo: _____

REQUIRED TOOLS

- Level
- Goggles
- Tape Measure

REQUIRED MATERIALS

- Silicone bathroom caulking (mildew resistant)

PREPARATIONS

Before installing a new Produits Neptune Rouge bathtub, we strongly recommend following the installation checklist and hiring a certified plumber to handle the installation.

Visually inspect the bathtub to make sure it has not been damaged during transport. In case of damage, do not proceed with the installation.

Make sure the bathtub is the model that you ordered, that its dimensions are correct and that the location of the drain corresponds to the plans.

Ensure that the floor of the bathroom is level and it is able to withstand the weight of the bathtub once filled with water (about 450 kg or 1000 lb). THE FOUR LEGS OF THE BATHTUB SHOULD BE IN CONTACT WITH THE FLOOR.

To protect the bathtub during installation, cut a piece cardboard in the package and place it in the bottom of the bathtub.

If your bathtub has a protective plastic film, do not remove it before having finished the installation. If necessary, remove the film temporarily in order to install the faucets. Also remove the film from where it may remain stuck, or lodged post installation. To remove the film, soak a cloth with isopropyl alcohol and wipe the entire surface of the adhesive film.

If the bathtub is equipped with adjustable metal legs, they must first be installed by screwing them into the metal opening beneath the bathtub.

BATHTUB INSTALLATION

1. Clear and clean the space around where the bathtub will be positioned so as to avoid damage to the bathtub during installation.
2. Check the level and the strength of the floor where the bathtub will be positioned. A bathtub filled halfway with water can weigh up to 450 kg (1000 lb) and the floor must be strong enough to support this weight.
3. The basic installation of plumbing (pipes and drain/water supply) must be performed by a qualified plumber prior to installation of the bathtub.
4. **To hook the drain to the floor drain, we strongly suggest to have an access underneath the bathtub or to use a floor drain specific for this installation (type 123-Connect D111). In this case, please refer to its installation guide.**
5. **If installing a deck-mounted faucet, do so at step 10 of this guide.**
6. Temporarily set the bathtub in its intended location, ensuring that the drain hole is aligned to the floor drain and then draw the contour of the bathtub on the ground.
7. Check the level and adjust if necessary by screwing or unscrewing the legs beneath the bathtub (maximum adjustment of 1" - 25 mm) and ensuring that the bathtub is always resting on all four legs while minimizing the space between the skirt and the floor (the skirt can rest on the floor but shall in no way support the weight the bathtub).
8. Lock the bathtub legs into position by tightening the adjoining nut once an accurate acceptable level is confirmed.
9. Lay the bathtub on its side having previously laid cardboard packaging the ground to protect the surface of the bathtub. Be sure to use a piece of cardboard without staples to avoid damaging the surface the bathtub.
10. Tighten the seal ring of the floor drain to the end the drain and if necessary, install the faucets using the its installation guide.

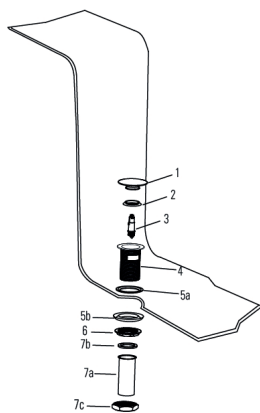

1. Plug
2. Cap Seal
3. Opening Mechanism
4. Strainer
- 5a. Putty ring
- 5b. Seal
6. Mounting Nut
- 7a. Drain pipe (1.5")
- 7b. Gasket
- 7c. Tightening Nut

11. Apply a bead of silicone to the entire circumference of the skirt and the bathtub legs. We also recommend setting circle of silicone to seal the drain.

12. Using a pencil, mark the wall studs directly under the lip of the deck. (Fig.2) If you intend to set the bathtub in a mortar bed, the position of the feet should be marked too.

Fig. 2

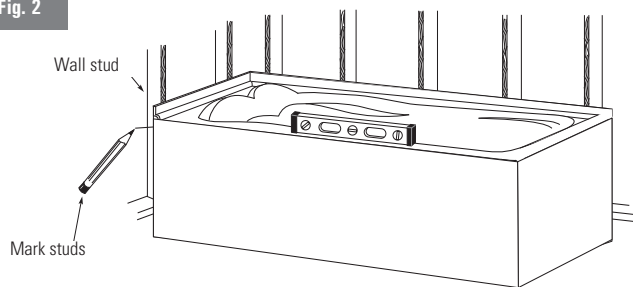

13. Remove the bathtub so that you have access to the walls.
14. Cut supports for the bathtub deck from 1" x 2" stock. The supports should be long enough to support the entire length of the bathtub. These supports are fastened to the wall studs with the top of the support at the level of the marks from step 12. (Fig.3)

***For the installation of the Belgrade bathtub, it's necessary to provide the space for the faucet on the support which will be fixed to the wall studs.**

Fig. 3

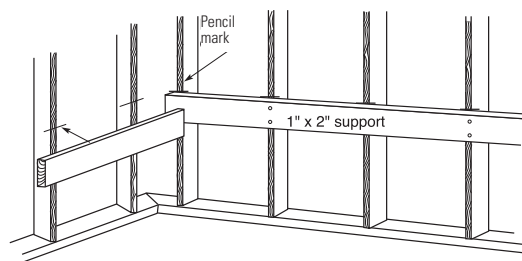

15. Silicone should now be applied under the legs to attach to the floor and reduce the risk of squeaks. (Fig.4) Note: A bed of mortar strongly recommended to decrease the flexion of the bottom of the bath.

Fig. 4

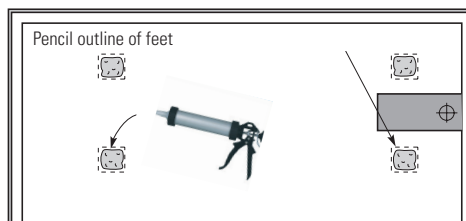

16. Apply a generous bead of construction adhesive along the top of the 1" X 2" support strips. (Fig.5) This will prevent the bathtub from shifting and also compensate for the unevenness of the fiberglass reinforcement under the deck.

Fig. 5

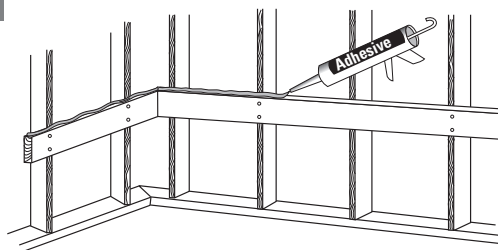

17. Set the bathtub into position. Check that the bottom of the deck comes into contact with the support strips. **If you opted to use a mortar bed**, check that the mortar has spread and that the feet are supported. Add more mortar if necessary. **If you did not use a mortar bed**, the shims should be replaced under the feet, and glued in place with construction adhesive. **Note: Do NOT fix feet to floor using nails or screws.**
18. When installation is complete (including plumbing installation), seal the bathtub onto the podium using silicone.

ROUTINE CLEANING

To protect the acrylic finish from Produits Neptune, it must be cleaned with a mild dish soap such as Dawn or Sunlight or a specifically designed acrylic detergent.

NEVER USE ABRASIVE POWDER (VIM, AJAX, COMET, etc.), PETROLEUM DISTILLATE OR OTHER STRONG SOLVENTS TO CLEAN THE BATH.

STAIN REPAIR

If you have a particularly resistant stain, you can use isopropyl alcohol to try and remove it (isopropyl alcohol is toxic, so always follow the safety instructions that come with it and wear rubber gloves).

MINOR SCRATCH REPAIR

Small superficial scratches can usually be removed by using an automotive polishing compound such as NuFinish or Meguiar's mirror glaze.

MAJOR DAMAGE REPAIR

Major damage, including chips and cracks in your bathtub, can often be repaired by a qualified technician. Your Produits Neptune dealer can put you in contact with such a qualified professional.

TROUBLESHOOTING

PROBLEM	SOLUTION
Water remains around the bathtub rim or drain..	Check that the installation is level and that the bathtub is sitting firmly on its feet. (Drain slope is built into the bathtub.) Shim with adjustment wedges if necessary
Bathtub bottom moves during use.	The bathtub is not sitting firmly on its feet. Shim with adjustment wedges.
Protective plastic film will not come off.	Use isopropyl alcohol.

123 Connect

DROP-IN DRAIN INSTALLATION KIT



DROP-IN DRAIN INSTALLATION KIT FOR YOUR FREESTANDING BATHTUB

FEATURES

- **Quick, easy and clean reestanding bathtub installation.**
- No access panel required.
- Allows for an installation as close to the wall as possible.
- Plate can be uninstalled if adjustments are needed.
- Fits with 1 ½" males, 1 ½" females or 1 ½" threaded bathtub drains.
- Reusable cap for more than one test air pressure, if necessary.
- Made in Canada.

INSTALLATION TIPS

- Use 5" hole saw to cut sub floor (not included). Cutting template included. Secure Deck Flange with 6 screws (not included).
- Do not cut the brass tailpiece as this may cause a leak.

SYSTEMS INSTALLATION

Blower must be installed under the floor or in a nearby cabinet.

A minimum space of 2" around the blower is necessary so that the air can be renewed constantly and thus allow air circulation with the ambient air.

During automatic purge, the blower automatically starts a purge of about 1 minute and a half, 20 minutes after the blower is off.

SYSTEMS CONNECTION

The electrical connections must be done by a licensed electrician to ensure that your installation is safe and complies with the applicable building code in your area.

Your system must be connected to an independent 110/120 volt circuit, protected by a class A ground fault circuit interrupter.

*In Canada only: Each electronic component must be connected to the electrical panel by a junction box, refer to your local electrical code.

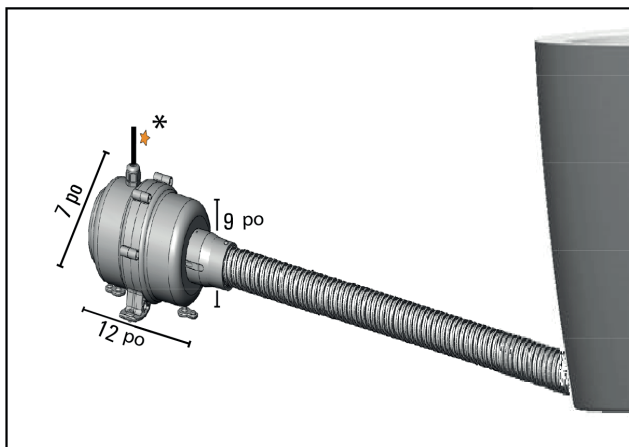
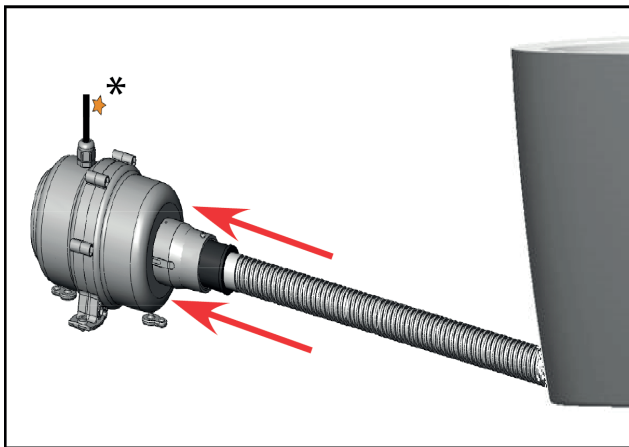
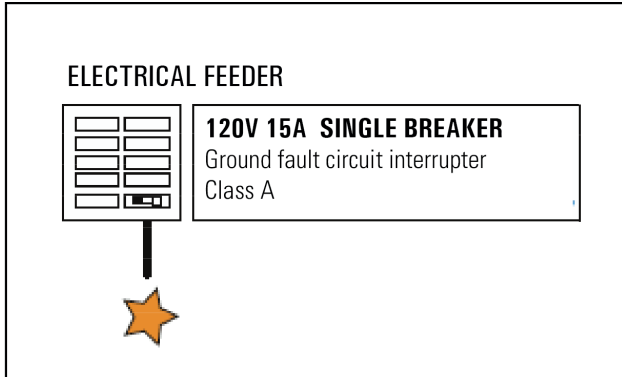

RECEIVER MODULE INSTALLATION

System only activates using the remote control.

1. Plug in the cable as show on the drawing.
2. Once it's connected, the remote control is ready for synchronisation.

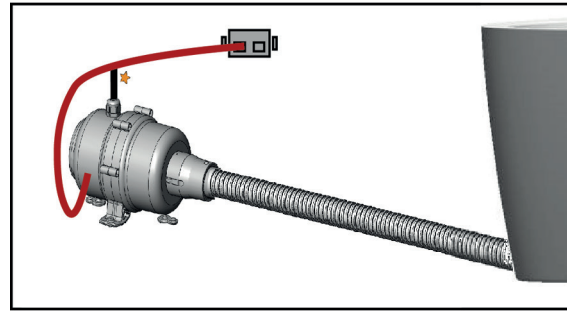

SYNCHRONIZATION

1. Once the system has been connected, the remote control must be synchronized with its receiver module.
2. Switch off the main breaker or unplug the system and switch it on again.
*From this moment, you have 15 secondes to proceed with the synchronization.
3. Press simultaneously on the buttons 2 and 3 of the remote for 4 seconds.

The remote control is now synchronized and ready to use. If the synchronization is not successful the first time, you should resynchronize, starting at Step 2.

The remote control :





- Is completely sealed and waterproof.
- Floats.
- Responds within 15 feet.
- Is equipped with extra long batteries.

IMPORTANT

In order to obtain the best reception, we recommend to not install the receiver module next to the faucets or metal piping.

Location of the receiver module must be easily accessible from the outside of the bathtub for maintenance.

OPERATION

1 ON / OFF BLOWER	
	First press: The blower starts Second press: The blower stops
2 INCREASES THE BLOWER	
	Press and hold to increase the blower speed. Release pressure at the desired speed.
3 DECREASES THE BLOWER	
	Press and hold to decrease the blower speed. Release pressure at the desired speed.
4 PULSE CYCLES	
	First press: Wave - Speed will vary gradually maximum to minimum. Second press: Pulse - Speed will alternate straight between the minimum and maximum. Third press: Return to maximum speed.

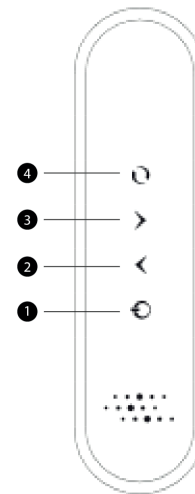

Integrated 20 minute timer.

TROUBLESHOOTING

PROBLEM	SOLUTION
Electronic control fails to operate.	<ul style="list-style-type: none"> • Check the electrical power supply. Reset circuit or replace fuse if necessary. • Check Ground Fault Circuit Interrupter (GFCI). Reset if tripped. • If the system has been in operation for a long time it is possible that the thermal protection switch has shut off the motor. Turn off the system and wait 30 minutes for it to cool, then try again. • Check the connections between the blower and the control module. • When the circuit breaker is reset or when there is a power failure, synchronize the command with the module.
Motor will not stop/ only some functions on the electronic control pad are working.	<ul style="list-style-type: none"> • Let the keyboard dry and check if the problem persists.
Excessive noise from blower.	<ul style="list-style-type: none"> • Most of the noise from your Rouge-Air or Mass-Air system actually comes from the movement of the water. • Check that the blower is firmly secured. • Make certain that there are no obstructions close to the intake of the blower, and that it has an adequate supply of fresh air.
Blower runs but no air comes out through the jets	<ul style="list-style-type: none"> • Check that the main air hose from the blower to the manifold is properly connected. Reconnect and tighten clamps if necessary.
Air outlets in jet heads are blocked.	<ul style="list-style-type: none"> • If the air outlets of a jet head are obstructed with soap or other residues, fill the tub with water and brush them gently with a toothbrush. Turn the system ON then OFF several times. • Remove caps (Mass-Air & Rouge-Air) and ball bearing and clean with cotton swabs. Use a rubber head hammer for reinstallation. • If the problem persists tap the jet heads with a spoon while the blower is running (Mass-Air system only).

WARRANTY

Our warranty does not cover damage caused by:

Lightning, fire, misuse, neglect, poor maintenance, thermal shock (flames, cigarettes, boiling water ...), damage following to delivery (contact from transport, handling ...), misuse, natural or chemical corrosion.

All alterations or modifications on a Produits Neptune Rouge bathtub automatically nullify all warranties. In the event of breakage, Produits Neptune Rouge must be informed within ten (10) days following the damage.

In keeping with manufacturer standards, the warranty is limited to the repair or replacement of the bathtub. No compensation may be claimed from the manufacturer resulting from loss of use, time, income, miscellaneous fees, inconvenience, materials, workmanship or any costs of removal or replacement of a defective product.

No other agreements or implicit promises are included in this warranty.

PRODUITS NEPTUNE ROUGE QUALITY

Your product has been inspected and tested by our specialists and is compliant with our high Produits Neptune Rouge quality standards.



UPC

Our products have received UPC certification.



ETL CERTIFICATION

Our products and their components have received ETL certification, which attests to their quality and reliability.

Intertek

WARRANTY

Each Produits Neptune Rouge product has been subjected to rigorous quality controls and we guarantee that it conforms to the highest quality standards. In order to ensure a trouble-free installation, we strongly recommend that you read the installation manual and our warranty terms joined with the product carefully before beginning any work. Our warranty covers parts and labor for repairs only and does not cover additional costs related to defective product replacement.

BATHTUBS

ROUGE ACRYLIC SHELL: Produits Neptune Rouge guarantees that acrylic units are free of any defects in materials and workmanship under normal use and service for a period of ten (10) years starting from the initial date of purchase by the owner/user, contractor, or builder from an authorized dealer.

DRAINS

ROUGE DRAIN: Limited 4-year warranty on finish (parts).

PARTS:

Limited 1-year warranty against manufacturing defects.

SYSTEMS

Limited 10-year warranty (parts and labor) against manufacturing defects; jets, pipes, fittings, electronic control pads, blowers, black box, remote controls, wiring, etc. and leaks related to manufacturing defects.

Limited 5-year warranty against manufacturing defects related to colored trims inside the bathtub.

IMPORTANT!

- When a showroom product is sold, the warranty period begins on the date of purchase from Produits Neptune Rouge by the retailer.
- For commercial use, all products have a 1-year warranty against manufacturing defects.
- The Produits Neptune Rouge warranty is solely for the personal household use of the original owner/user and starts on the date of purchase from Produits Neptune Rouge by the retailer. The warranty will take effect when the original owner/user presents the original bill of sale. The warranty is not transferable to subsequent owners. All products replaced or repaired by a qualified and certified technician during the warranty period will still be covered for the remainder of the original warranty.
- This warranty shall not apply in the case of non-compliant or incorrect operating procedures, breakage or damage caused by normal wear and tear, fault, negligence, abuse, misuse, misapplication, improper maintenance, alteration or modification of the product, as well as chemical or natural corrosion, fire, flood, or any other fortuitous event. This warranty shall not apply to stains or malfunctions caused by natural disaster, ferrous water, hard water or salty water.
- Like any product of lasting quality, Produits Neptune Rouge products and accessories require a certain amount of upkeep to preserve their finish. Clean your new Produits Neptune Rouge with a mild soap, rinse thoroughly with warm water, and dry with a clean, soft cloth. Never use cleaning products containing abrasive agents, ammonia, sodium hypochlorite, bleach, acid, wax, alcohol, or solvents. Failure to comply with these maintenance instructions may invalidate the Produits Neptune Rouge warranty.
- No return on products sold in liquidation.
- No warranty on products sold in liquidation.
- No return on products sold more than 3 months ago.
- 1-year guarantee on purchased parts.