

Visit <https://configurator.mtibaths.com> to create your custom counter-sink.

Petra 3 CS

MODEL 803
Bowl: 17.75" x 11.75"
WALL MOUNT or VANITY MOUNT
SculptureStone®

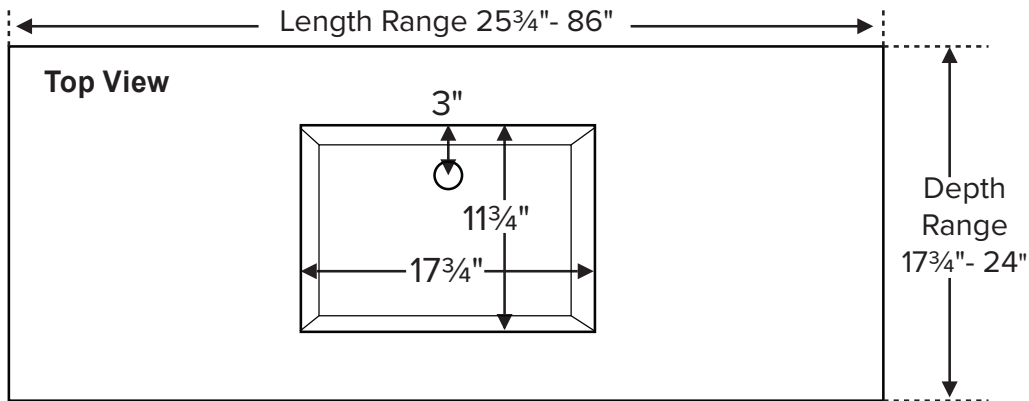

NOTE: Counter-sinks with a length of 36" and under have a maximum depth of 23".

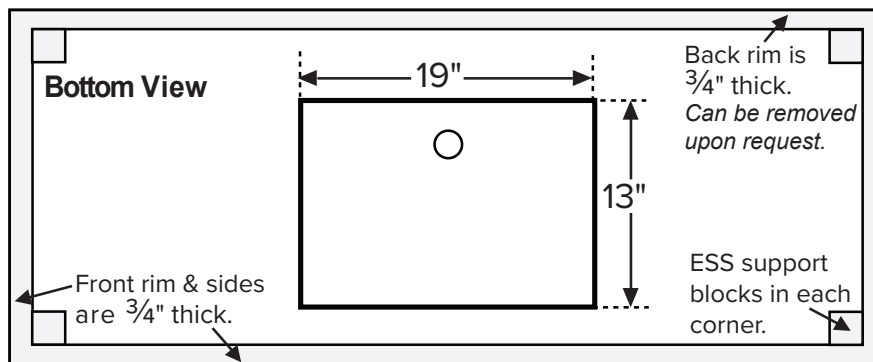
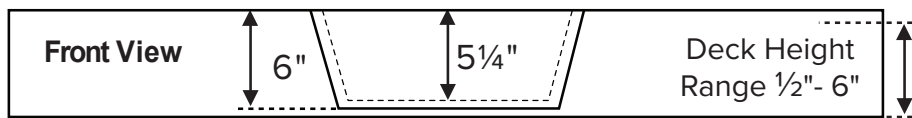

ORDERING AND INSTALLATION

- Counter-sinks with a length of 36" and under have a maximum depth of 23".
- Due to the handcrafted nature of this product, please allow for a tolerance of $\pm 1/4$ " for overall dimensions and $\pm 1/2$ " for bowl placement.
- Corner support blocks are necessary only when deck height is over 1".
- All sides planned to install against a wall or other structure will be unfinished. Sides indicated as visible on order will be finished.
- Carefully review inside vanity specifications to ensure that there is proper clearance to accommodate the bowl, drain and optional integrated overflow, if applicable.
- Please take into consideration the thickness of material under the countertop when positioning sink bowl, using a deck-mounted faucet or adding an integrated overflow.
- Outside of overflow housing protrudes approx. $3/4$ " from the bowl and may impact bowl placement.

• Check for accessories before discarding packaging.
 • All product measurements are $\pm 1/2$ ".
 • Specifications and configurations are subject to change without notice.
 • Measurements herein supersede all others published prior to publication date below.

MTCS-803

©2025 by MTI Baths, Inc. Modification Rights Reserved

See Product Manual for details.
 MTI's Customer Service
 Monday-Friday 8am-6pm EST
 800-783-8827 or service@mtibaths.com



Rev. 12 20 2024