

25" x 22" x 11.5"

Universal
Part # - MTL-110

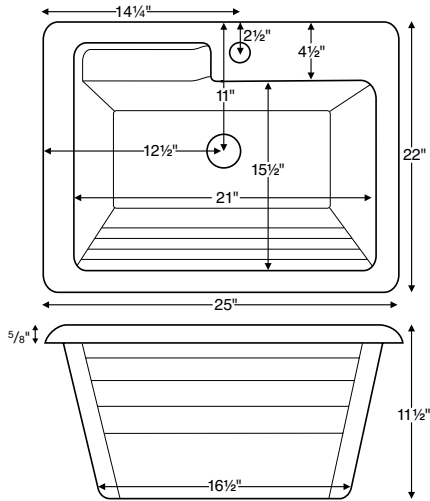

OPTIONS

- White (MTLS110W) **\$550**
- Biscuit (MTLS110B) **\$560**
- Quick Ship / Priority. *Call for availability.* (QUISINKSH) **\$235**
- Shipping Weight: 15 lbs

CSA # MTL-110

25" x 22" x 12.5"

Versatile
Part # - MTL-120

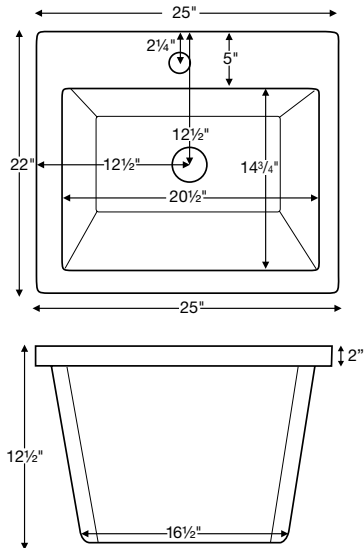

OPTIONS

- White (MTLS120W) **\$570**
- Biscuit (MTLS120B) **\$585**
- Quick Ship / Priority. *Call for availability.* (QUISINKSH) **\$235**
- Shipping Weight: 17 lbs

CSA # MTL-120

CONSTRUCTION AND STANDARD FEATURES

- Due to the particular shape of this sink, MTI recommends having the product on site before attempting any cut-out in counter top material.
- Single-bowl design; accommodates 3.5" kitchen sink drain
- Can be undermounted or caulked directly to the countertop without the use of clips or channels. **SPECIFY WHEN ORDERING.**
- Durable cast acrylic shell is extremely scratch- and stain-resistant yet renewable because the color goes all the way through the material.
- No holes drilled if undermounting. Installer will drill onsite.
- Non-porous surface makes cleaning and sanitizing faster and more effective.
- Multi-layered reinforced backing of thick fiberglass / resin / titanium.
- At least 30% thicker and stronger than other makes.
- 2-year limited residential; 1-year commercial warranty.

- Before discarding box, check for accessories that may be packaged inside.
- All product measurements are ±1/2".
- Specifications and configurations are subject to change without notice.
- Measurements herein supersede all others published prior to publication date below.

See the Installation & Operation Manual for more details.
MTI's Customer Service: Monday-Friday 8am-6pm EST
800-783-8827 or service@mtibaths.com

